



For over 30 years, Vaniman has established a tradition of Quality, Service, and Innovation for all the products it manufactures for the Dental Industry.

Starting with the original Accumulator™. Pre Filter , Vaniman's complete line of General and Specialty dust collectors, Micro Abrasive Blasters, Air Purification, and Electronic Waxing products, provide our customers the quality the industry has come to expect.

In addition, Vaniman has been involved in the CAD / CAM revolution right from the start and offers high-quality, fully integrated dust collecting systems used by all major milling machine manufacturers.

Our Service department provides direct customer/technician interaction which streamlines technical assistance, as well as suggestions for properly configuring a product to achieve its optimal performance.

Innovation has been the cornerstone of Vaniman Manufacturing over the last 30 years. The Engineering Staff is continuously striving to provide the customer with the most robust, economical, and effective products available.

Vaniman remains committed to providing the Dental Industry the highest quality of products and service available through our worldwide dealer network.

Vaniman Manufacturing Co.  
www.vaniman.com  
sales@vaniman.com  
Phone: 760-723-1498  
Fax: 760-723-6990  
P.O. Box 74, Fallbrook, CA  
92088-0074

**To be purchased:**  
**MB Maschinen GmbH**  
**Zimmerwiesenweg 2/2a**  
**D-63599 Biebergemuend**  
**Tel. +49 6050 8702**  
**mb-maschinen@t-online.de**  
**www.mbmaschinen.de**



# Vanguard Gold 2x

## The original single station dust collector

- High speed turbine technology producing high suction
- Whisper quiet operation at 55 decibels
- Low maintenance design
- Additional filtration options
- Multi-speed
- High suction for heavy duty use
- 1 year warranty
- Interface cords available

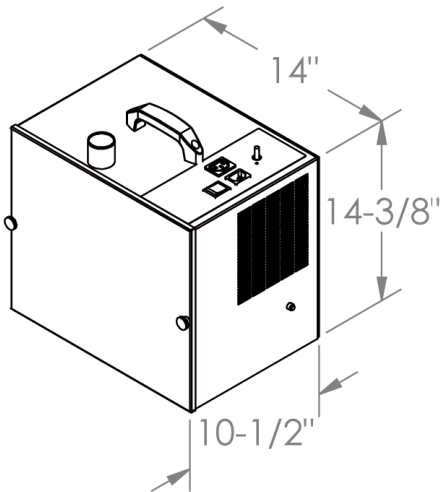

**Dust Collector Bags**  
High quality bags in an economical 5-pack. Cloth bag is designed for long life in all Vaniman bag-type dust collectors.



# StoneVac II

## The most versatile dust collector in the industry...

- HEPA Filtration Captures 99.97% of Dust at 0.3 Microns
- Ultra quiet design
- Can be configured as a Two Station System\*
- Optional remote switch control
- 1 year warranty
- Interface cords available

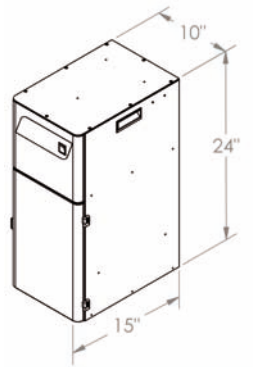

with **Twister**™  
TECHNOLOGY  
HIGH SPEED TURBINE SYSTEM

Hepa  
Filtration  
Captures  
99.97% of  
Dust at 0.3  
Microns

Exclusive  
"Electronic"  
Filter  
Maintenance  
System

Extra Large Dust Tray